

EARTH NETWORKS®



Sferic Siren

System Installation, Operation and
Maintenance Manual

Copyright

Copyright 2019, by Earth Networks, Inc.
All Rights Reserved.

Manual Copyright, 2019, by Earth Networks, Inc.

All Rights Reserved.

Information in this document is subject to change without notice and does not represent a commitment on the part of Earth Networks, Inc.

FCC Compliance

This equipment has been tested and found to comply with the limits for a Class B digital device, pursuant to part 15 of the FCC Rules. These limits are designed to provide reasonable protection against harmful interference in a residential installation. This equipment generates, uses and can radiate radio frequency energy and, if not installed and used in accordance with the instructions, may cause harmful interference to radio communications. However, there is no guarantee that interference will not occur in a particular installation. If this equipment does cause harmful interference to radio or television reception, which can be determined by turning the equipment off and on, the user is encouraged to try to correct the interference by one or more of the following measures:

- Reorient or relocate the receiving antenna.
- Increase the separation between the equipment and receiver.
- Connect the equipment into an outlet on a circuit different from that to which the receiver is connected.
- Consult the dealer or an experienced radio/TV technician for help.

Disclaimer

The procedures, methods, and hardware described in this manual are intended to provide general guidelines and instructions for installing the Earth Networks Sferic Siren. Each installation site is unique and each site may require special considerations that are beyond the scope of this manual. Any questions not covered within this manual should be directed to Earth Networks Technical Support at (800) 624-4205 or email support@earthnetworks.com

All procedures, methods, and hardware used to install an Earth Networks Sferic Siren must conform to all applicable building codes (national, state, and local). Installation subcontractors are responsible for complying with all applicable codes. Buyer and/or installer provided hardware must be equivalent or better (according to industry standards) than that specified in the Earth Networks Installation Manual.

The buyer/installer is responsible for any damage caused by installation of the Earth Networks Sferic Siren.



THINK SAFETY FIRST!



Warranty. The Seller warrants the hardware purchased by the Buyer against defects in workmanship and materials for a period of one (1) year from date of delivery under this contract. The Seller shall, at its sole option, either repair or replace defective items. Buyer is responsible to return of defective items to Seller by means specified by the Seller. The Buyer shall bear all shipping expenses. Packing of defective items for return is responsibility of Buyer. Damage due to natural causes (storms, lightning, flying debris, etc.) is not covered by this warranty. Damage resulting from Buyer negligence or mishandling of hardware and software is not covered by this warranty.

Table of Contents

Copyright	3
FCC Compliance	3
Disclaimer	3
Thank You!	8
Introduction	8
Plan Ahead!	9
Safety!.....	9
Installation.....	10
Site Evaluation	10
Determining Horn Locations.....	10
Determine a Suitable Informer Location.....	10
Getting Started	11
Outdoor Components	11
Indoor Components.....	10
Tools Required.....	10
Additional Tools/ Materials Needed	11
Site Preparation	11
Installing Outdoor Equipment.....	13
Assembling the Horn(s).....	13
Outdoor System Wiring	16
Power Connections (all horns)	16
Horn Connections.....	16
Strobe Connections.....	16
Data Connections (base horn only).....	17
Installing Informer	18
Informer Wiring.....	18
Data Cable Connections	18
Additional Informer Connections	19
Configuration	19
Overview	19
Configuration via Web Browser Interface	19
Computer Configuration	19
Login	20
System Server and Unit ID Assignment.....	20
Change Config User Password.....	21
Static IP Address, Site ID, and Location Assignment	23
Backup Configuration.....	26
Informer Operating Instructions	27

General Information.....	27
LED Indicators.....	27
Keypad.....	29
Testing and Training.....	29
Troubleshooting.....	27
Maintenance.....	28
Additional Information.....	28
Specifications.....	29
Informer Specifications.....	29
Horn Specifications.....	29
Wiring Diagram.....	30

Thank You!

Thank you and congratulations on acquiring the Earth Networks Sferic Siren. The Earth Networks Sferic Siren provides additional lightning safety on your property through an audible warning when lightning is detected within predefined parameters.

By installing and operating the entire Earth Networks system, you become an essential part of the Earth Networks program, an integrated network of weather stations comprising the largest weather monitoring system in the world.

Introduction

The Earth Networks Sferic Siren is the most advanced localized automated weather warning system available. The system minimizes nuisance alerts and provides real-time warnings based on current environmental conditions in the area.

The alert system is comprised of an indoor alert device, the Informer, and one or more outdoor notification horns (with strobe light). The Informer connects to the Earth Networks alert system server via the internet to receive lightning alert notices. The Informer activates a base outdoor horn via a wired connection. Where additional horns have been purchased a wireless radio transmission is sent, activating them.

The indoor Informer contains a loud internal speaker with an adjustable volume level to alert personnel indoors.

Plan Ahead!

Read this entire manual before beginning installation. The Earth Networks Sferic Siren installation can be straightforward and easy to complete if all steps are followed closely.

The most important aspect of preparation is safety. Installation of the Earth Networks Sferic Siren requires working with electrical cable, drilling through walls or other dense support structures, standing on ladders, and possibly, walking on roofs. **Please carefully read the following section on “Safety.”**

Please also pay close attention to the section on “**Site Evaluation.**” A complete site evaluation determines proper placement of the Sferic Siren components and will prevent the need to have to re-locate the system due to inadequate coverage.

All additional parts needed (such as ladders, drills, bits, etc.) should be assembled and inspected before beginning installation. ***Earth Networks cannot accept responsibility for damage caused by these tools so all safety precautions should be strictly adhered to,*** including the use of leather gloves and goggles when appropriate.

For questions, call Earth Networks Technical Support at (800) 624-4205 or email support@earthnetworks.com

Safety!

Only qualified personnel should install the Sferic Siren.

While installation of the Sferic Siren components are not particularly difficult, it does usually require installation near the rooftop and working with electrical wiring, which presents some amount of risk.

To limit risk to self and property, this manual should be thoroughly read and understood before beginning installation. Adhere to all warnings on the unit and in the operating instructions.

Installation must conform to national, state, and local building code requirements with the most stringent guidelines being adhered to.

The Sferic Siren should only be installed by someone comfortable with being on a high ladder or rooftop and who is authorized by the site to perform the installation. Roof and ladder safety is crucial!

Allow only qualified Electricians to make electrical connections. Take all reasonable safety precautions –

double checking a power cable connection could save a life.

Stay as far away from other electrical wiring as possible. **Never allow the mast, cabling, a drill bit, or any other item to contact electrical wires or conduit. Injury or death could result.**

A qualified installer will need to securely mount the outdoor unit to a supporting structure capable of sustaining the weight of the unit (approximately **50 pounds**) by using appropriate tools and hardware. Failure to properly secure the Sferic Siren Horn could result in the unit separating from the support structure and falling. This would not only damage the system, but could injure anyone standing nearby.

Installation

Site Evaluation

Placement of the individual warning system horns is critical for full area coverage. The following guidelines should assist with choosing the proper placement sites.

Determining Horn Locations

The following guidelines should be used when determining to position the horn(s):

- Horns have a 500 yard radius of coverage (line of sight).
- Location(s) must have access to power within 20 ft.
- Horn(s) must be at least 8 ft. off the ground and clear of obstructions (Trees, Roofline, etc.).
- The horn location(s) must have a significant structure to mount the horns to that can handle the load (new or existing).

Determine a Suitable Informer Location

When picking a location for the Informer first consider the following criteria:

- Place the Informer away from electrically noisy devices to avoid interference.
- A wired Ethernet connection is required for the Informer. Ethernet wire runs must be within 300' from the nearest network switch.
- Place the Informer in an area where the alert can be clearly heard by necessary personnel.
- Do not place the Informer near water.

- The Informer needs to be located within six feet of an AC power receptacle.

Getting Started

Carefully unpack, set out, and identify each part and inspect for damage. **If any damage is noticed, please call Earth Networks Technical Support at (800) 624-4205 or email support@earthnetworks.com**

Outdoor Components



Outdoor Control Box



Sound Dispersion Cone



Outdoor Horn



Mounting Hardware

Indoor Components



Informer and power supply

Tools Required (minimum)

- 1 Philips #2 Screwdriver
- 1 Philips #2 Short Screwdriver “Stubby”
- 1 Slotted Screwdriver (2mm blade)
- 2 9/16” Box Wrenches
- 1 7/16” Box Wrench
- 1 3/8” Nut Driver or equivalent wrench
- 1 Pair of Pliers
- 1 Pair Wire Stripper/Cutters
- Cable Ties

Additional Tools/ Materials Needed (Not supplied by Earth Networks)

- Heavy-duty drill with bits sized up to 1-1/4" – bits must be appropriate for material being drilled into (masonry, wood, metal, etc.) and must be long enough to penetrate the support walling from exterior to interior (possibly as much as 10" or more).
- Fish Tape to pull cable through wall
- Electrical Tape to tape the ends of cables for protection and to hold connectors and cables together.
- An adjustable ladder
- Metal saw for cutting mast if necessary
- 10 ft x 1.5 in. inside diameter (ID) galvanized rigid conduit (GRC). 1 piece or more for each horn, depending on the mounting height (available at most home improvement stores).
- Mounting platform for each horn (non-penetrating roof mount, tripod mount etc...)
- Additional mounting hardware as needed
- Silicone
- Data cable (for connection from base unit to informer)
- Cat 5 LAN cable (for connecting Informer to network)
- 18 awg wire for the Strobe

Site Preparation

The install site needs to have the following in place to ensure a successful installation:

- Power available for all components
- Internet access for all components with the following outbound connections allowed: port 80
- Access to a licensed electrician during install for hardwiring power to the horn(s)

Installing Outdoor Equipment

Assembling the Horn(s)



1. Connect the left and right mounting brackets to the bottom of the E-Horn using the provided screws.



2. Attach the square pole bracket to the left and right mount brackets using the lock washers, flat washers, nuts and screws provided.



3. Place the pole clamp and strobe bracket on to the square pole bracket using the longer U-Bolt provided along with the lock washers and nuts.

****NOTE:** Two of the U-Bolts are shorter and are to be used with the dispersion cone.



4. Next attach the strobe onto the strobe mounting bracket and secure it with the strobe nut.

****NOTE:** Please make sure to attach the wire be used for install prior to doing this.



5. Locate the mounting brackets for the Outdoor control box. Attach the mounting brackets in the orientation shown using the provided screws and nuts.



6. Next take the two U-Bolts and attach them to the brackets as shown using the nuts provided.

7. Now the components can be mounted to the mast
 - a. The assembled Horn with Strobe should be mounted to the top of the mast.
 - b. The Sound Dispersion Cone should be mounted so that the point is 2" below the Horn.
 - c. The assembled Control Box should be mounted lower on the pole.
8. Attach the assembled horn and mast to the pre-determined existing (solid) structure.



Fully Assembled Sferic Siren (**Repeat this procedure for each additional horn purchased**)

Outdoor System Wiring

All Sferic Siren site locations need to be hardwired for 120/240 VAC with at least a 15 amp circuit.

Power Connections (all horns)

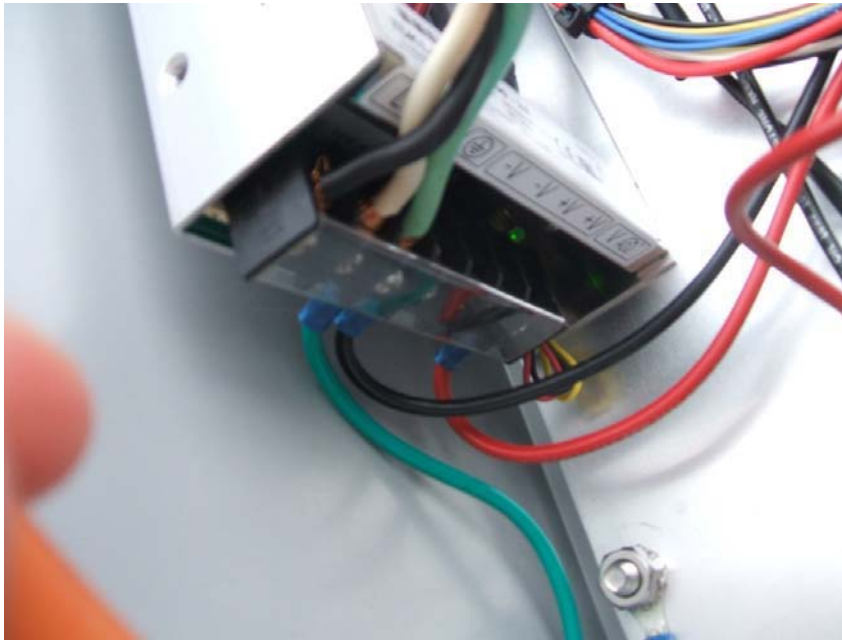

This is an example of wiring the main power into the horn enclosure. **Horns need to be hardwired by a licensed electrician**

Ensure that the wires are securely attached to the power supply mounting block and that bare wire is not exposed. Replace plastic cover guard over the wiring block.

Horn Connections

Please refer to the wiring diagram found at the end of this manual.

1. The Red wire will connect to the Omron on the Left Side of Q0
2. The Black wire will connect to the ground block found on the left side of the main board.

Strobe Connections

Please refer to the wiring diagram found at the end of this manual.

The Red wire will connect to the Omron on the right side of Q1.
 The Black wire will connect to the ground block found on the left side of the main board.

Data Connections (base horn only)

The base horn location will also require wiring the base horn to the Informer via a four wire data cable.

Wire Color	Informer Connection	Omron Connection	Signal
Blue	Relay Out #1	I0	Pulses on Alert
Yellow	Relay Out #2	I1	Pulses on All Clear
Red	Relay Out #3	I2	Pulses on Cancel
Black	Relay Out Com1-3	(-) or Ground Bar	Ground

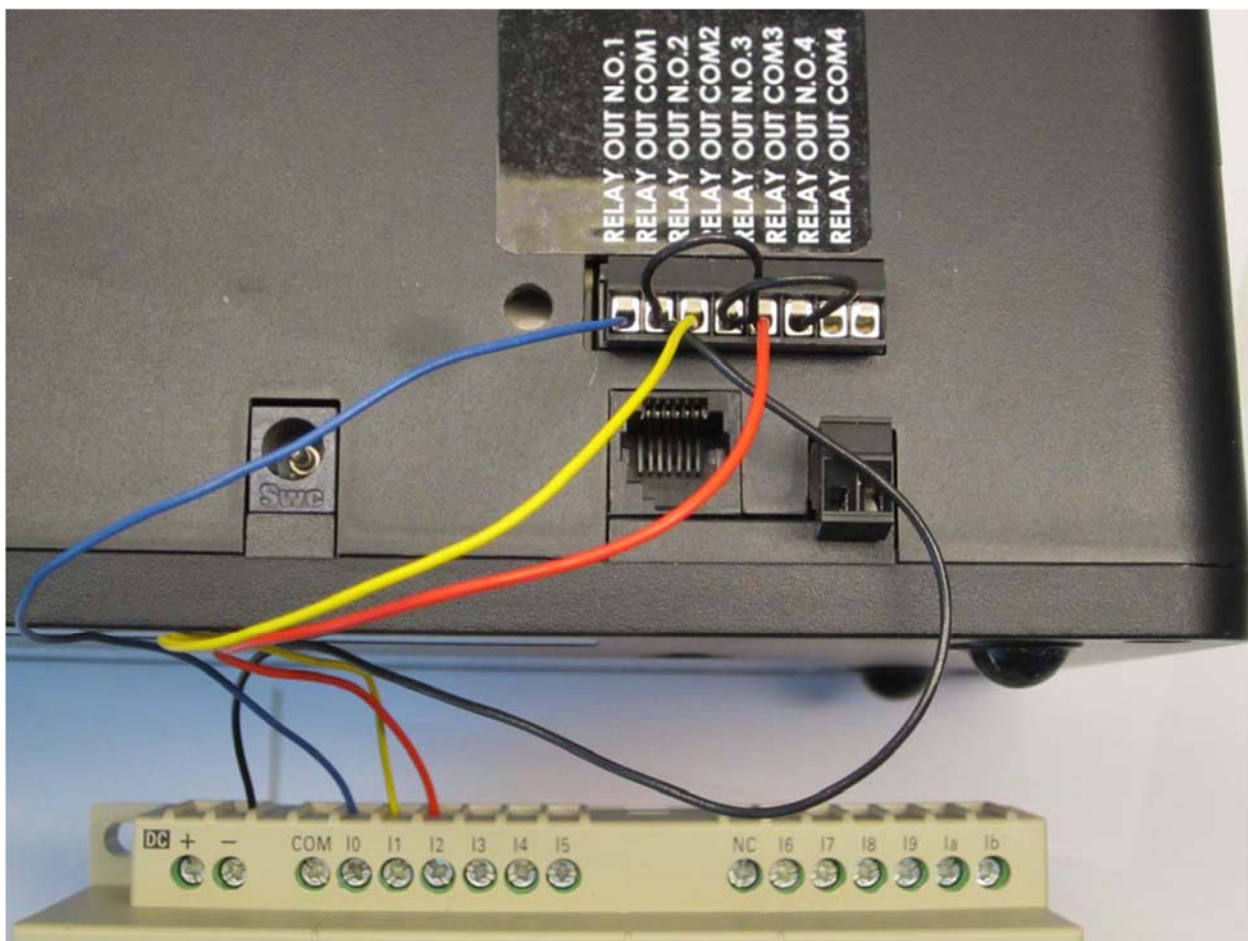

Installing Informer

Informer Wiring

The Informer requires 120/240 VAC. The Informer will also need network access and will be connected to the base site outdoor horn via a data cable.

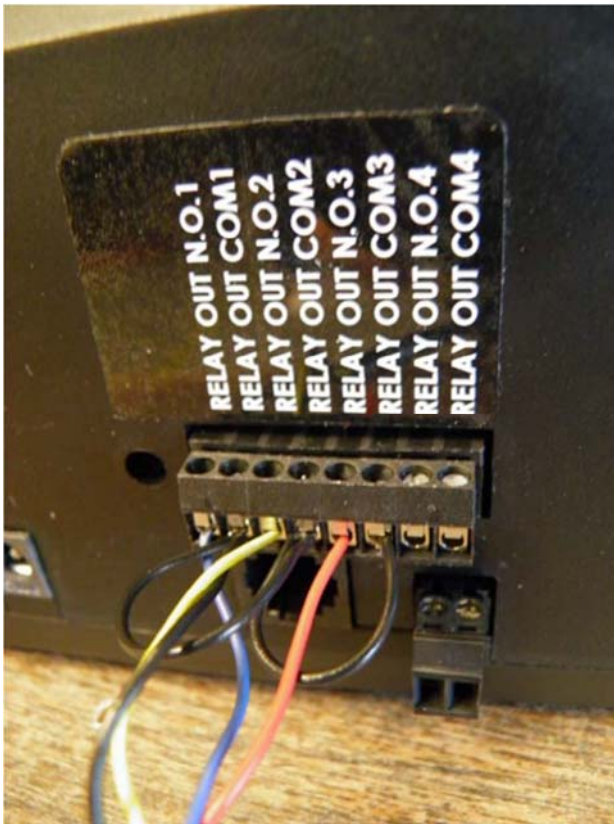

Data Cable Connections (example above)

Securely connect all data cable and jumper wires to the Informer as outlined below and the figure above.

Blue data cable wire - Relay out N.O. 1

Black data cable wire and 1 Black jumper wire - Relay out Com 1

Yellow data cable wire - Relay out N.O. 2

Black jumper from Relay out COM1 and another Black jumper – Relay out Com2

Red data cable wire - Relay out N.O. 3

Black jumper from Relay out Com2 - Relay out COM 3

Additional Informer Connections

Connect Ethernet cable to the back of the Informer.

Connect the Informer Power Supply into the wall receptacle.

Connect the power supply output connector into the Informer (power light should now be illuminated).

Configuration

Overview

Before using the Informer on your network, configuration must be performed by a System Administrator. The Administrator must be familiar with IP network equipment and this manual. Proper configuration settings are required for the network to be able to reliably communicate with the device and create a redundant, failsafe network architecture for your system.

The Informer can use a static IP address or it can be configured for DHCP. The factory default setting places the Informer in DHCP mode. The unit may be restored to this factory default setting with a hardware reset if the configuration information is lost.

The default username / password are: **User: config, Password: Informer-IP**. The config user has security rights to change the config user password. Usernames and Passwords are case sensitive.

Configuration via Web Browser Interface

Computer Configuration

In order to connect to the Informer via the web browser the Digi device Discovery tool (**dgdiscvr.exe**) must be downloaded from <http://support.earthnetworks.com>.

Once downloaded, run the tool to determine what IP address has been assigned to the Informer.

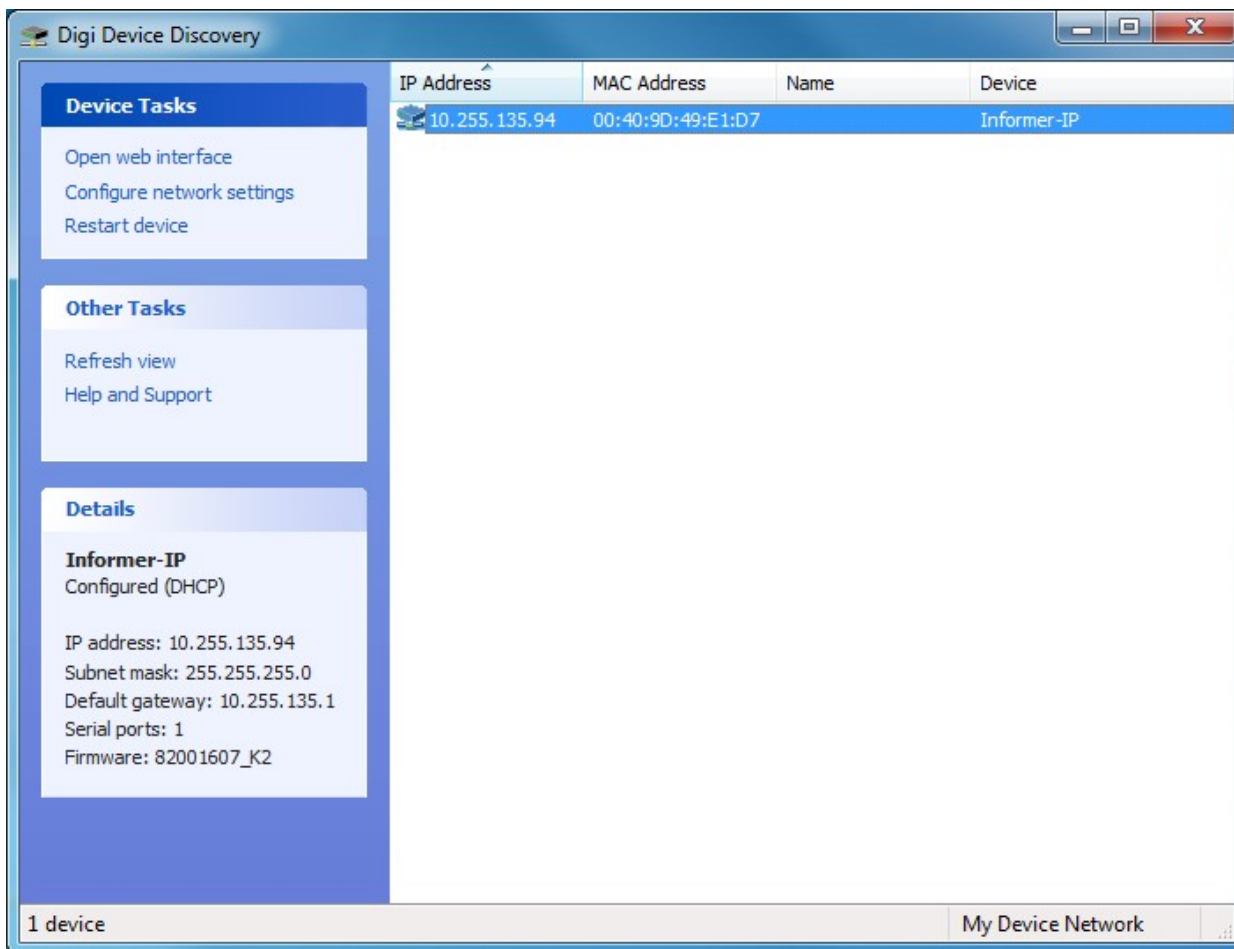

Double click your mouse on the Informer address displayed, and then proceed to Login

Login

After double clicking on the Informer IP address, the Login screen should be displayed

Enter the default **username and password** as follows:

Username: config (or pre-configured Username)

Password: Informer (or pre-configured Password)

Login to the Informer

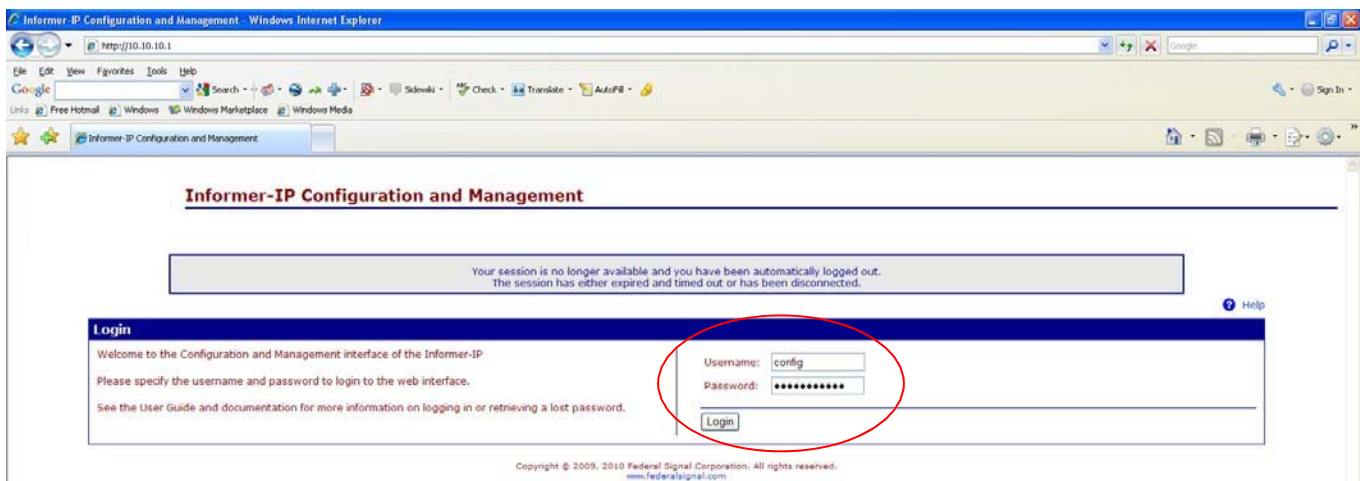

System Server and Unit ID Assignment

Once the Home page is displayed, select System from the Configuration menu on the left

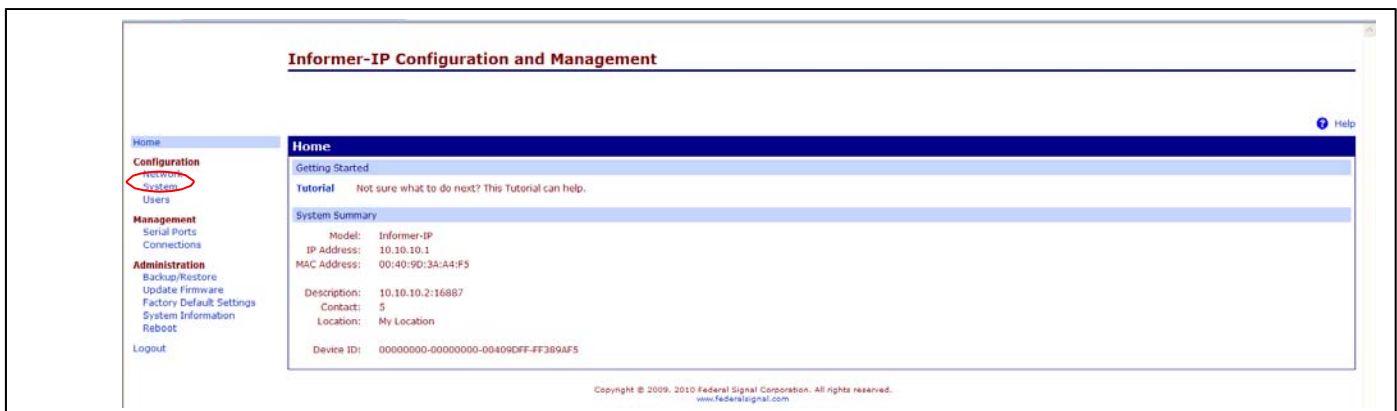

Enter 54647ca4a09d471c97c482824b53b17a into the Location field.

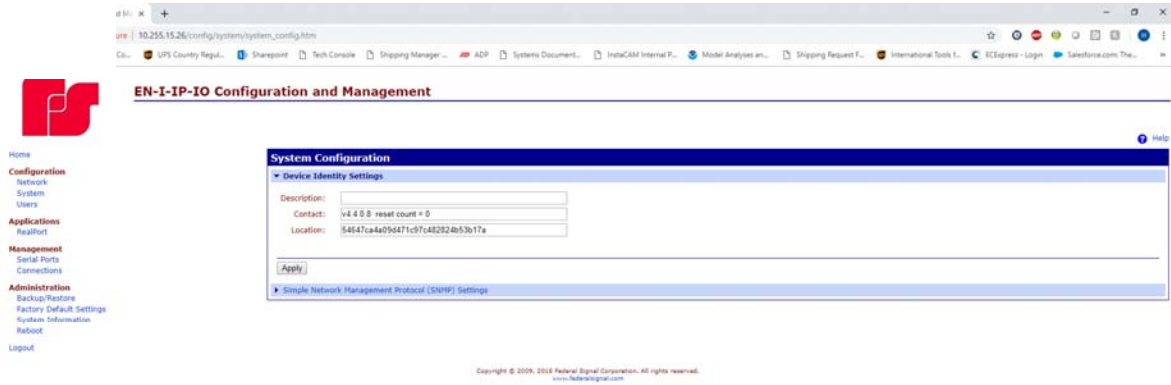

Change Config User Password

Change the Config user default password for security and store the new password and the network configuration settings in a secure location. The default password and original configuration can be restored by executing a Factory Default function. Select Users from the Configuration menu. Select the config user to change the password. Enter the New Password, Confirm and apply the new password.

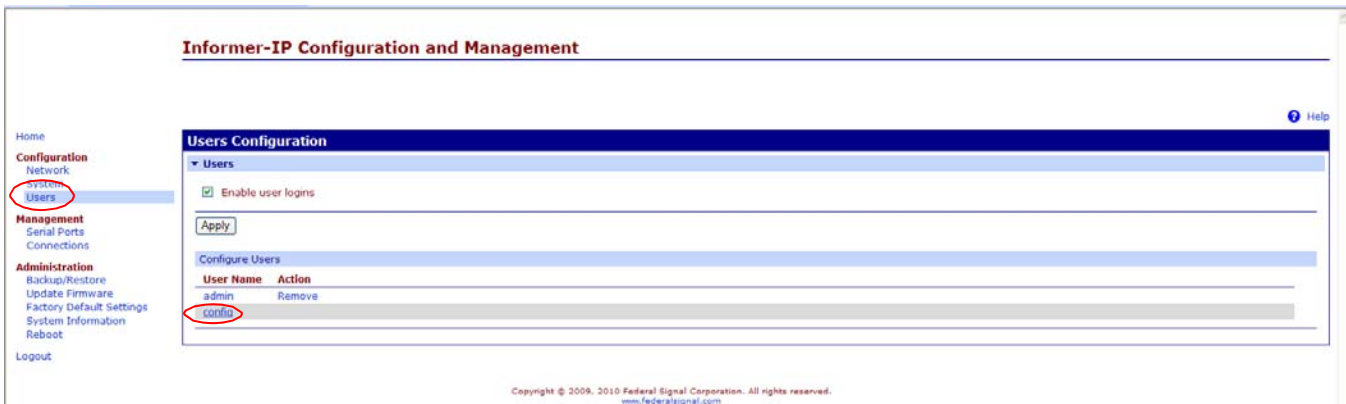

Static IP Address, Site ID, and Location Assignment

Click on the Network menu item and select: “Use the following IP address”
Enter the static IP address; Subnet mask and Gateway for the Informer. Select “Apply” once entries are complete.

Informer-IP Configuration and Management

Home

Configuration

- Network
- Serial Ports
- GPIO
- Alarms
- System
- Remote Management
- Users

Applications

- RealPort

Management

- Serial Ports
- Connections

Administration

- File Management
- Backup/Restore
- Update Firmware
- Factory Default Settings
- System Information
- Reboot

Logout

Network Configuration

▼ **Ethernet IP Settings**

Configure the network below. IPv6 settings are shown here for informational purposes.

IPv6

Site Local Address: none
Link Local Address: FE80::240:9DFF:FE49:E1D7

IPv4

Obtain an IP address automatically using DHCP *

Use the following IP address:

* IP Address: 10.10.10.1
* Subnet Mask: 255.255.255.0
Default Gateway: 0.0.0.0

Enable AutoIP address assignment

* Changes to DHCP, IP address, and Subnet Mask may effect your browser connection.

Apply

▶ Network Services Settings
▶ IP Forwarding Settings
▶ Socket Tunnel Settings
▶ Advanced Network Settings

Internet | Protected Mode: On

Select Advanced Network Settings to provide a host name and configure DNS servers. Select “Apply” once entries are complete.

Network Configuration

▶ Ethernet IP Settings
▶ Network Services Settings
▶ IP Forwarding Settings
▶ Socket Tunnel Settings
▼ **Advanced Network Settings**

The following settings are advanced settings used to fine tune the network connection and network interfaces. The default settings will typically work in most situations.

IP Settings

Host Name:

Static Primary DNS: 0.0.0.0
Static Secondary DNS: 0.0.0.0

DNS Priority: Static
Ethernet

Ethernet Interface

Speed: Auto Mode: Auto

TCP Keep-Alive Settings

Idle Timeout: 2 hrs 0 mins 0 secs (10 secs - 24 hrs)
Probe Interval: 75 secs (10-75)
Probe Count: 9 probes (5-30)

Apply

Internet | Protected Mode: On

The device must be rebooted for the IP address change to take effect using the Reboot menu item.

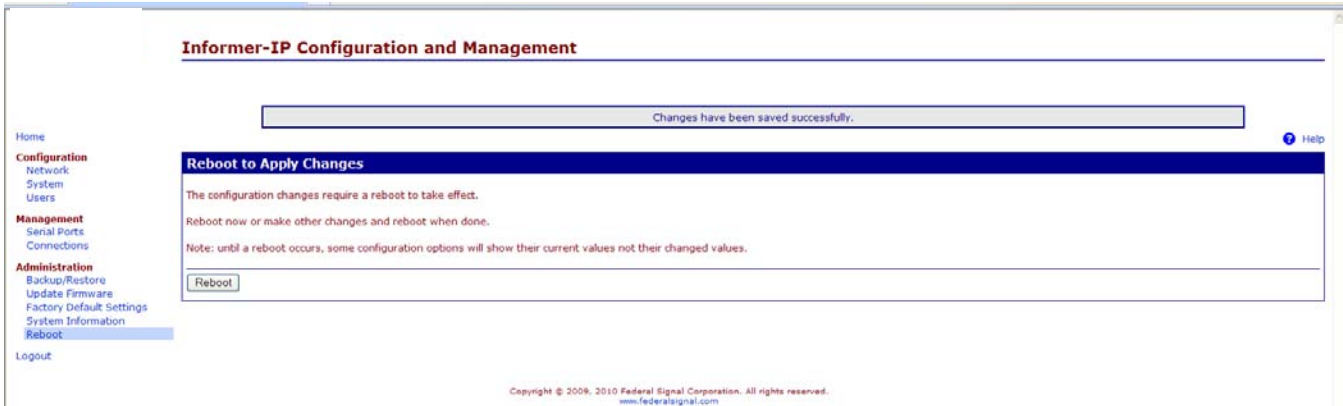

Verify that the IP address is change was successful by running the Digi Device Discovery tool again. You should see that the correct IP address is now showing. Place the Informer on your network and bring up your web browser. Type in the new IP address for your Informer, the Login screen should appear. Log in and verify that all of your settings are correct.

Backup Configuration

Once all configuration settings are complete, configuration settings can be backed up and restored using the Backup/Restore menu selection.

Informer Operating Instructions

General Information

The Informer must be configured correctly and tested before placing into service. Refer to the configuration section of this manual. If you are experiencing any difficulties with the Informer, contact your local Earth Networks service representative.

The following sections describe the various features and functions of the Informer.

LED Indicators

Power LED

The green power LED will turn on when power is connected.

Alert LED

The red Alert LED will Flash on and off at a 1 second interval when an Alert is received. The LED is reset when the All Clear or Cancel buttons are pressed or the Earth Networks server ends the Alert.

Trouble LED

The yellow trouble LED will turn on when the Alert Controller loses the connection to the Earth Networks Server.

Test LED

The Blue Test LED turns on Steady when a Test alert is received from the Earth Networks server. The Test LED will stay on for 10 minutes. This feature is useful to ensure the user can communicate with the Earth Networks server and that the Alert Console is receiving messages from the Earth Networks server.

Network LEDs

The Ethernet port has two diagnostic LED s.

Yellow - Link Status

Off - no link has been detected.
On - a link has been detected

Green - Port Activity

Off - the channel is idle.
Blinking - data is transmitted or received.

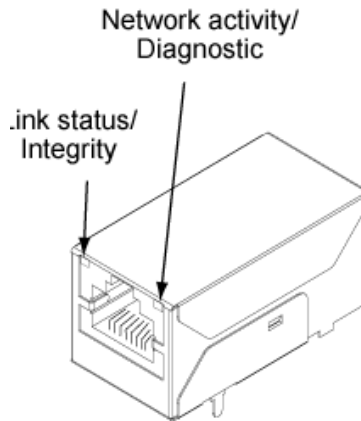

Keypad

The Informer includes a 5-button keypad and 4 diagnostic LEDs.

Volume Adjustment

To adjust the volume, press the **VOLUME** ↑ button to increase the sound volume. Press the **VOLUME** ↓ button to decrease the volume. A beep will be heard indicating the current volume level each time the volume buttons are pressed.

ALERT Button

The Alert button allows the operator to manually initiate an Alert. The Alert will be initiated at the Informer and activate all outdoor horns. The red Alert LED will light indicating that the Alert is active. The Alert will sound a 15 second horn blast and turn on a strobe light, on each horn, for the duration of the Alert.

ALL CLEAR Button

The All Clear button allows the operator to manually initiate an All Clear. The All Clear will be initiated at the Informer and activate the outdoor horns. The All Clear will turn on the strobe and sound three 5 second horn blasts then turn off the strobe and the Alert LED to indicate the Alert has ended.

CANCEL Button

The Cancel button ends the Alert Function turning off the strobe and Alert LED. The horn will not sound an all clear signal when the alert is cancelled with this button. The Cancel button can only be used to cancel manually initiated Alerts. The Earth Networks Alert Control System will automatically re-initiate alerts that have been manually cancelled. The 15 second horn blast will occur each time an alert is re-initiated.

Testing and Training

After the installation is complete, test the Informer and Alerting Horns to ensure the system is operating properly. Ensure all users are properly trained to use the system prior to putting the Informer into service.

Testing should be conducted on a regular basis per facility safety plans to ensure the equipment remains in working order and operators remain familiar with the use of the equipment

Troubleshooting

Informer Trouble Light is illuminated

- Check to see if other devices on the same network as the Informer are having problems.
- Verify that the LAN cable is securely connected to the Informer and the Network Device (switch/router).
- Verify that the Informer is properly configured.

No lights on the Informer

- Verify that the Informer power supply is fully seated into the outlet and the back of the Informer.
- Verify that the outlet for the Informer has power.

Informer sounds, but some or all outdoor horn(s) do not

If the base outdoor horn didn't sound

- Verify that the horn controller has power.
- Verify that the data cable connections at the horn controller and the Informer are properly connected.
- Verify that the horn is connected to the controller box.

Base outdoor horn sounds but optional horn(s) do not

- Verify power is on within the controller box.
- Verify that the horn is connected to the controller box.

If the problem persists contact **Earth Networks Technical Support (800) 624-4205** or support@earthnetworks.com

Restore Configuration to Factory Defaults

If the configuration details are lost or changed incorrectly and it becomes necessary to restore the Informer to factory default settings, a Power-On Factory Default procedure may be performed as follows:

1. Remove power from the Informer.
2. Press and hold down the Reset button.
3. Apply power while holding down the Reset button.

All local configuration settings will need to be re-entered before placing the Informer into service

Maintenance

There is little maintenance needed for the Sferic Siren as long as power and internet connectivity are maintained and the outdoor controller cover is tightly fastened.

Periodic inspections should be performed on outdoor components to ensure data and power cables are secure and undamaged. The outdoor controller should be inspected to verify it remains water-tight.

Additional Information

This product has been designed with safety in mind. However, if not properly installed and used, any electrical product can cause fires. To avoid such incidents, please be sure to follow these guidelines.

- Follow all general safety precautions
- In case of a system breakdown, discontinue use, unplug the unit and all other cables, and contact **Earth Networks Technical Support at (800) 624-4205 or email support@earthnetworks.com**
- In case of abnormal operation (Unit is emitting smoke or an unusual smell, water or other foreign objects enter the housing, the unit is dropped or damaged et. al):
 - Disconnect the power cable and other connecting cables.
 - **Contact Earth Networks Technical Support at (800) 624-4205 or email support@earthnetworks.com**

Specifications

Informer Specifications

Item	Specification
Audio Frequency Response	300 Hz to 3000Hz, +1 to -3dB per octave
Audio Output	½ watt into 8 ohms
Audio Distortion	< 5% @ 80dB, with 700 Hz tone
Ethernet Port	IEEE 802.3, 10/100 base-T Full/half Duplex auto-negotiating
Relay Outputs	Four Normally Open Relay Outputs, 5 amps @ 30VDC
Electro Magnetic Interference	Complies with FCC Title 47, Part 15
Operating temp range	-22F + 140F/ -30C + 60C
Tilt Speed	400 degrees/s (max.)
Power Requirements	120 VAC w/wall transformer
Power Consumption	5 amps
Dimensions	8" W x 5" D x 3.5" H/ 215.9mm x 127mm x 88.9mm
Weight	Approximately 2.8 pounds / 1.27 kg

Horn Specifications

Item	Specification
Enclosure	NEMA Type 4X, IP66
Power Supply AC Input	85-264VAC, 47-63 Hz/ 3.5A@115VAC, 1.7A@230VAC
Power Input DC	20 to 28 VDC, 70 ma Standby, 4A with horn and strobe
Power Supply DC Output Voltage	22-28 VDC
Power Supply DC Output Current	8.4 amps DC max
Battery Backup	5 days without AC power
Strobe Light Output	175,000 Candela Peak
Flash Rate	65-95 / minute
Horn Acoustic Output	117dB Omni-directional
Horn Current	3 A
Mounting	1.5" pipe
Wind Load	142lbs (@110mph,30')
Dimensions	39" x 12" x 23.5" H/ 991 mm x 305mm x 597 mm
Weight	50 lbs, 22.7 kg (without 1.5" pipe)
Operating Temperature Range	-40° to +122° F / -20° to + 55° C

Wiring Diagram

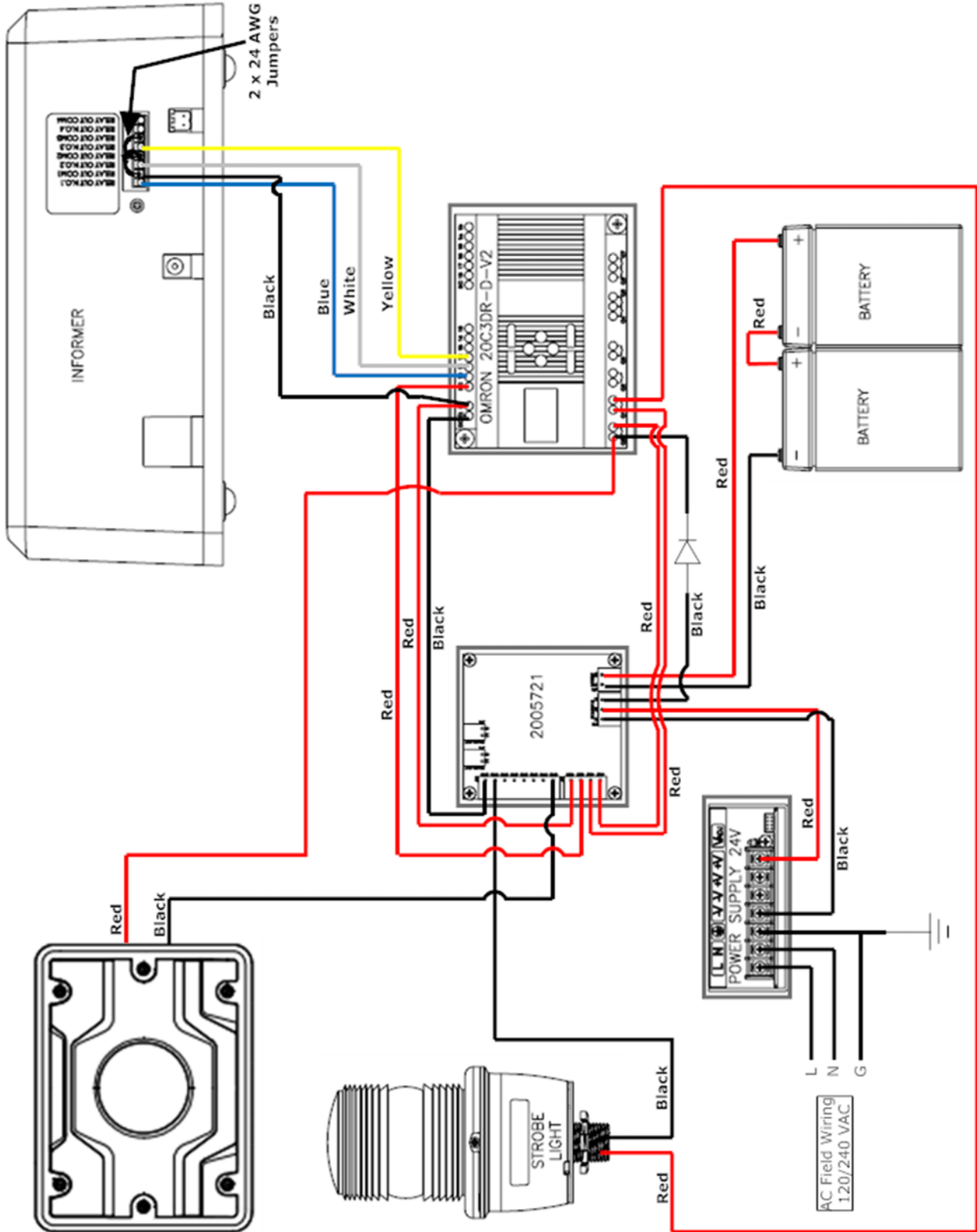

Optional Radio Wiring Diagrams

Receiver Diagram

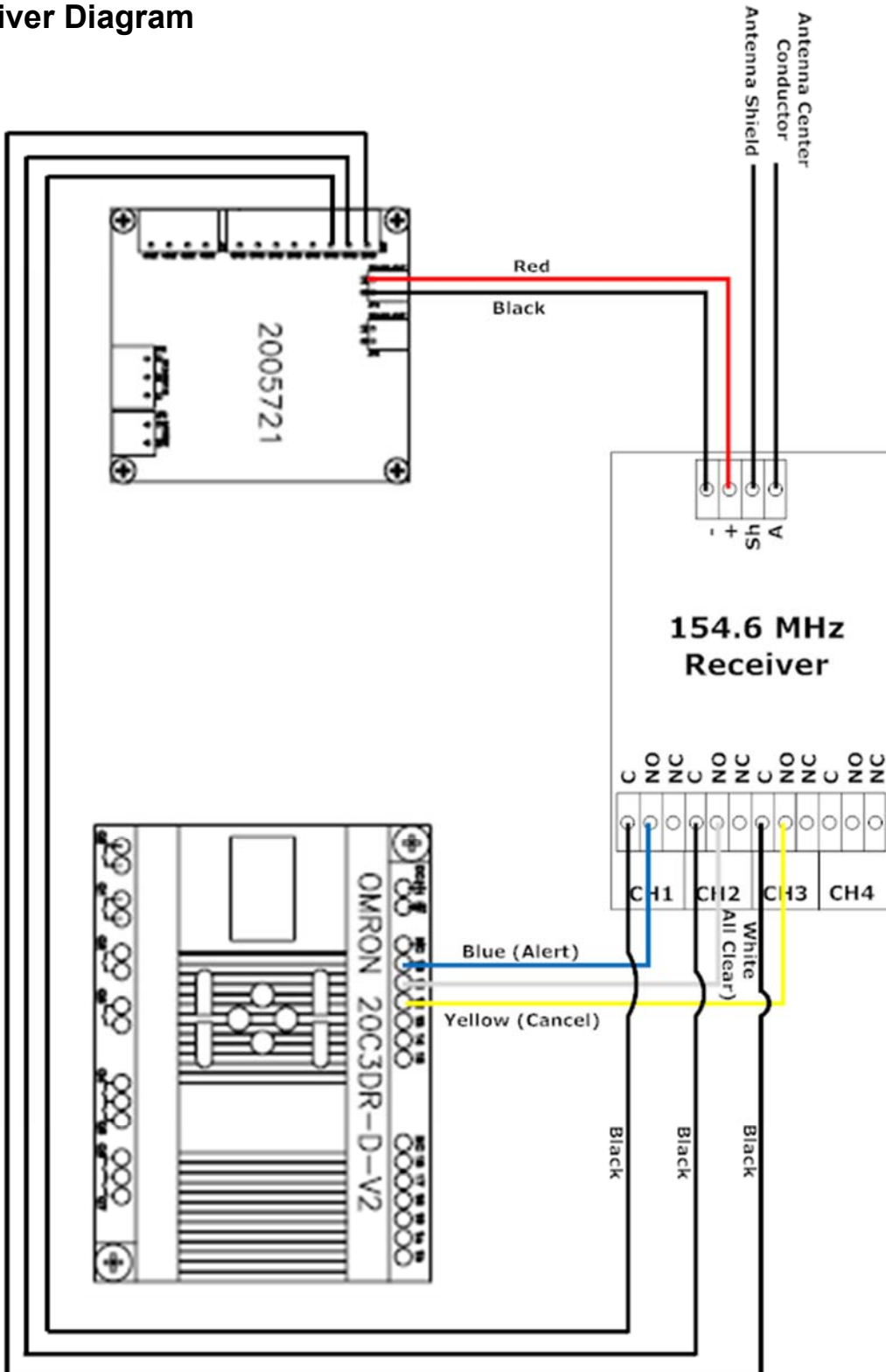

Transmitter Diagram

